

Certificate of Analysis

NA4 Glycan

Cat. #: CN-NA4-20U (2*10U) / CN-NA4-10U

Batch: B83N-03

Size: 20 µg (2*10 µg) / 10 µg

Expiry Date: 23 Mar 2023

Alternative Names

A4G4

Glycan Structure

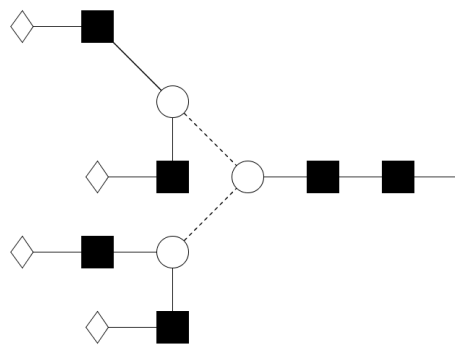

Oxford Notation

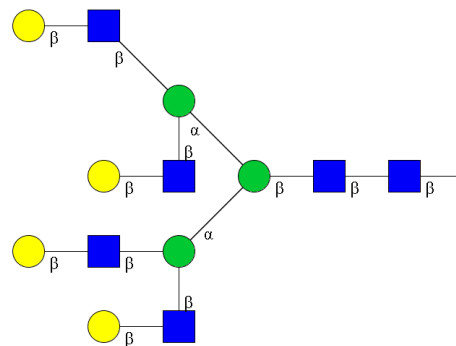

CFG Notation

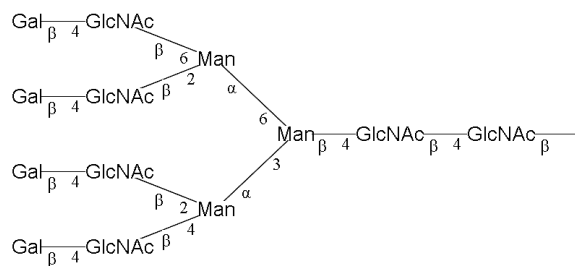

Text Notation

Purity: 91.1% pure as assessed by HILIC Glycan chromatography of 2AB labeled glycan (see Fig 1).
HPAE-PAD, MS and NMR included as supporting data.

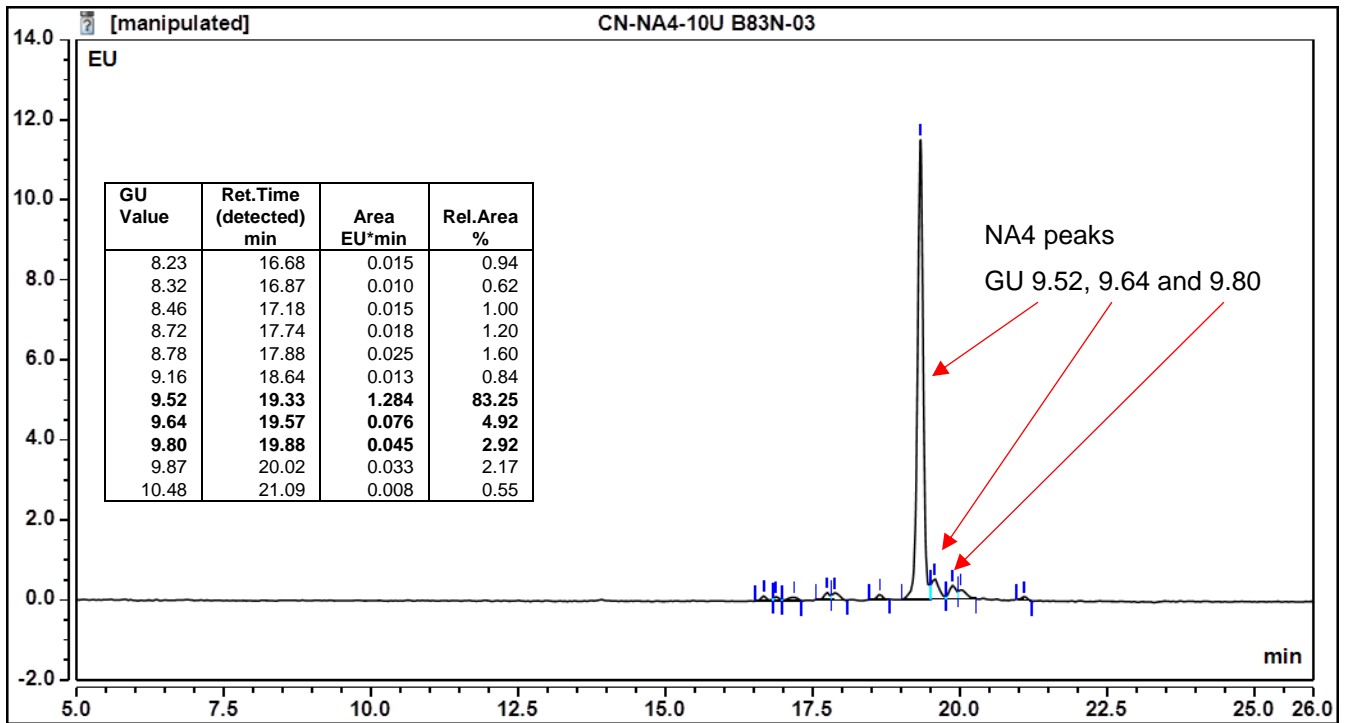

Figure 1: HILIC column UPLC chromatogram of 2AB labeled NA4 glycan (CN-NA4-10U, Batch B83N-03)

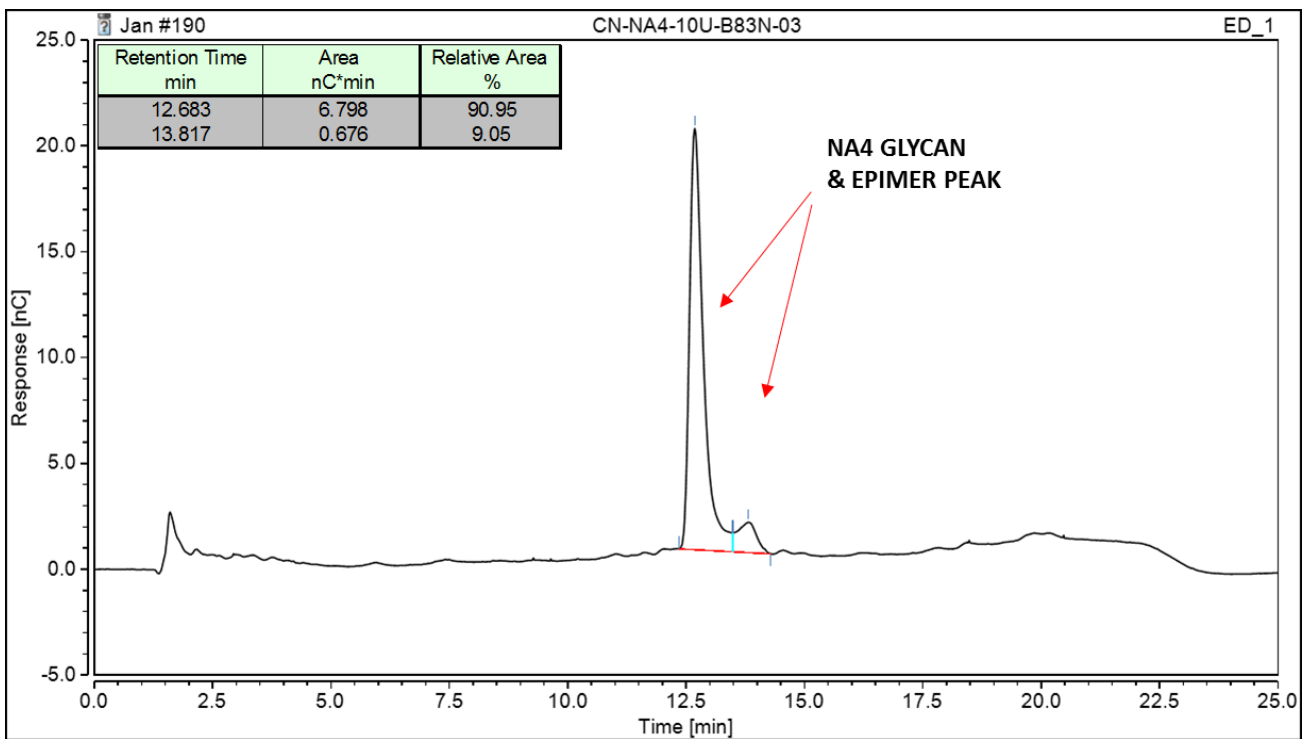

Figure 2: HPAE-PAD HPLC Profile of NA4 (CN-NA4-10U, Batch B83N-03)

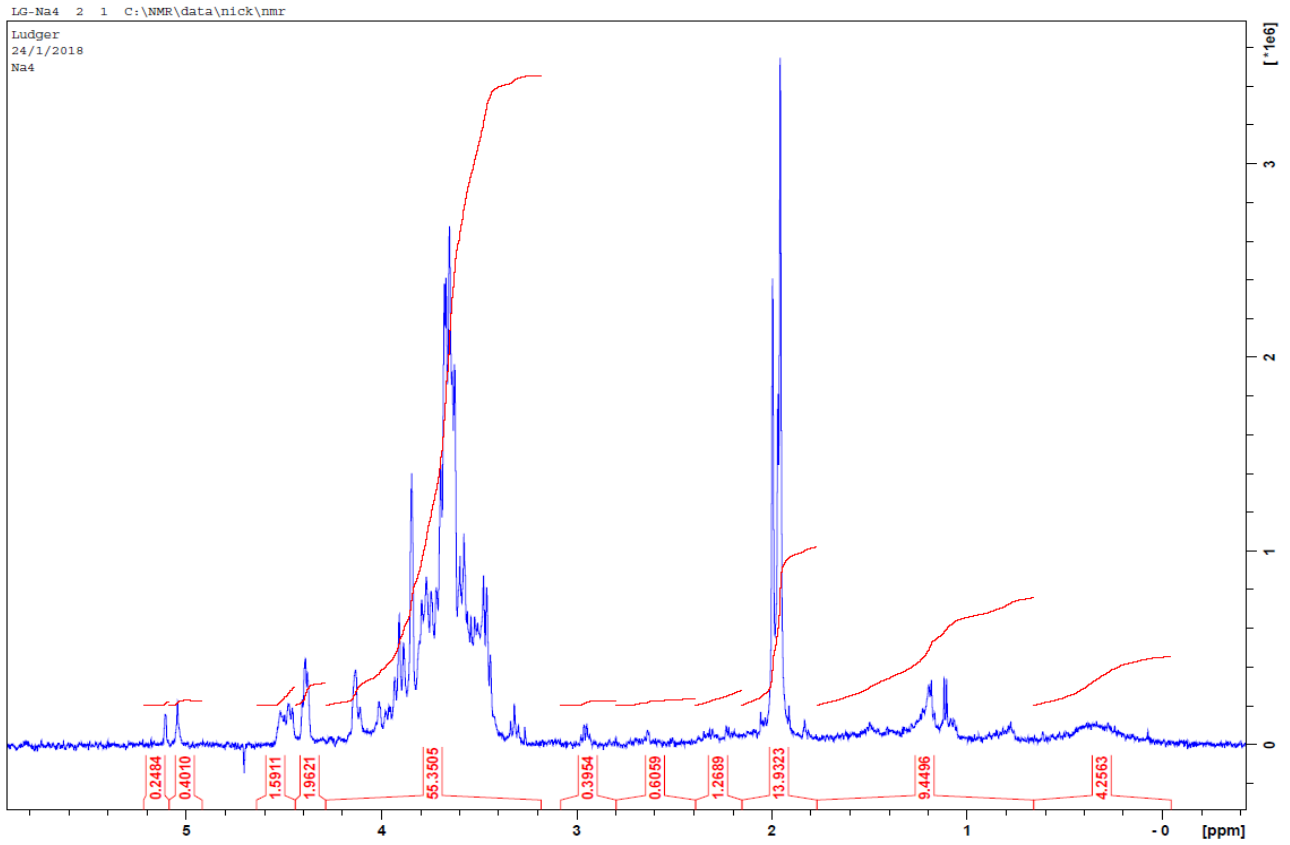

Figure 3: 500MHz ¹H-NMR of NA4 glycan BULK (CN-NA4-BULK, Batch B829-02)

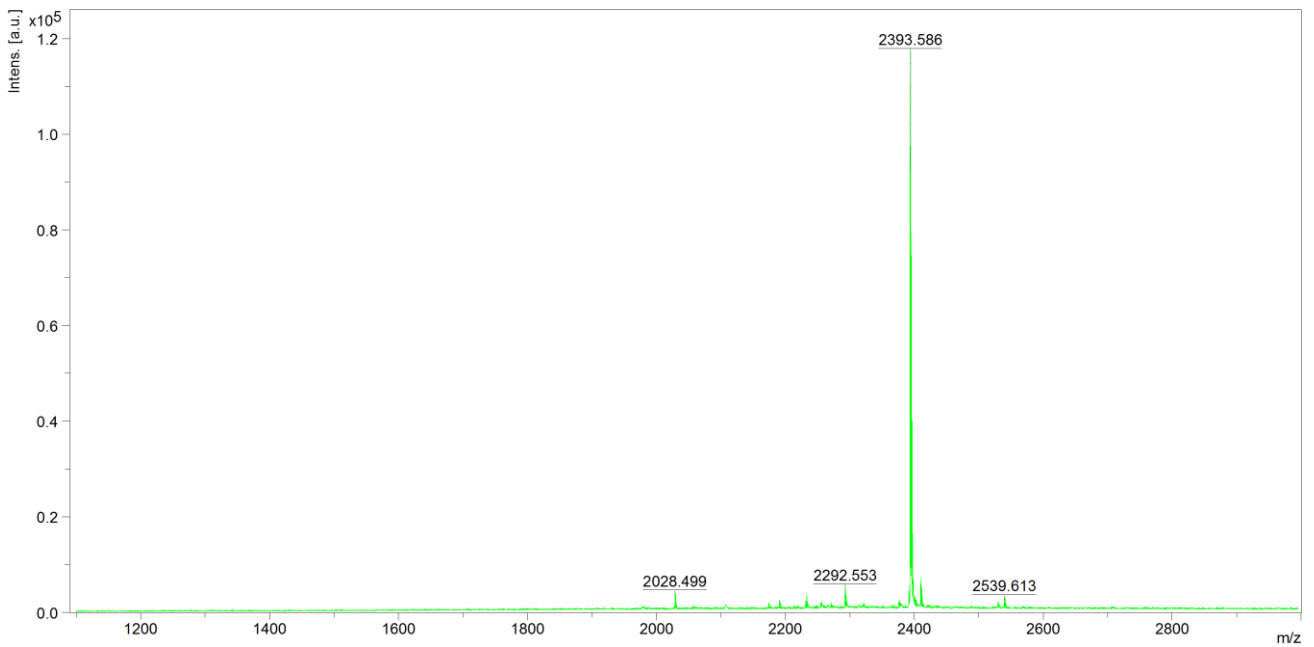

Figure 4: Positive ion mass spectrum of NA4 glycan (CN-NA4-10U, Batch B83N-03). Theoretical mass 2393.8 Da [M+Na]⁺