

Certificate of Analysis

LudgerPure™ 2AB Labeled NA2 Glycan

Cat. #: CAB-NA2-01

Batch: B335-02

Size: approx. 100 pmol

Structure

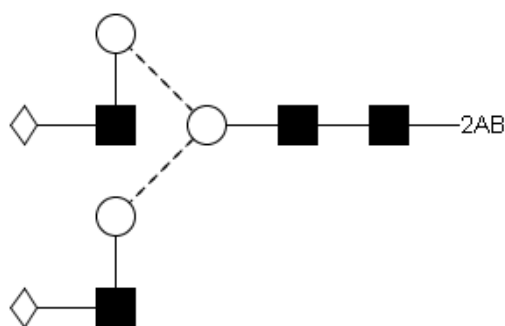

Oxford Notation

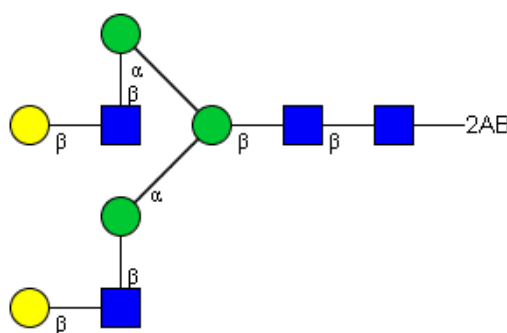

CFG Notation

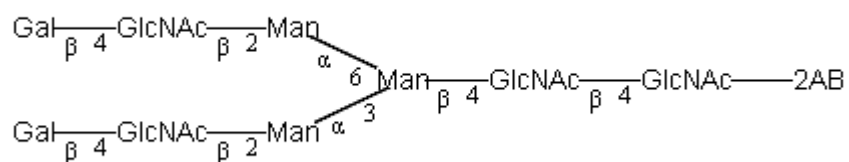

Text Notation

Purity: 92.8% 2AB labeled NA2 glycan, as assessed by HPLC - see Fig 1.

Amount: Sample vial determined to contain 121 pmols NA2 glycan – Test performed 11 Mar 2013.

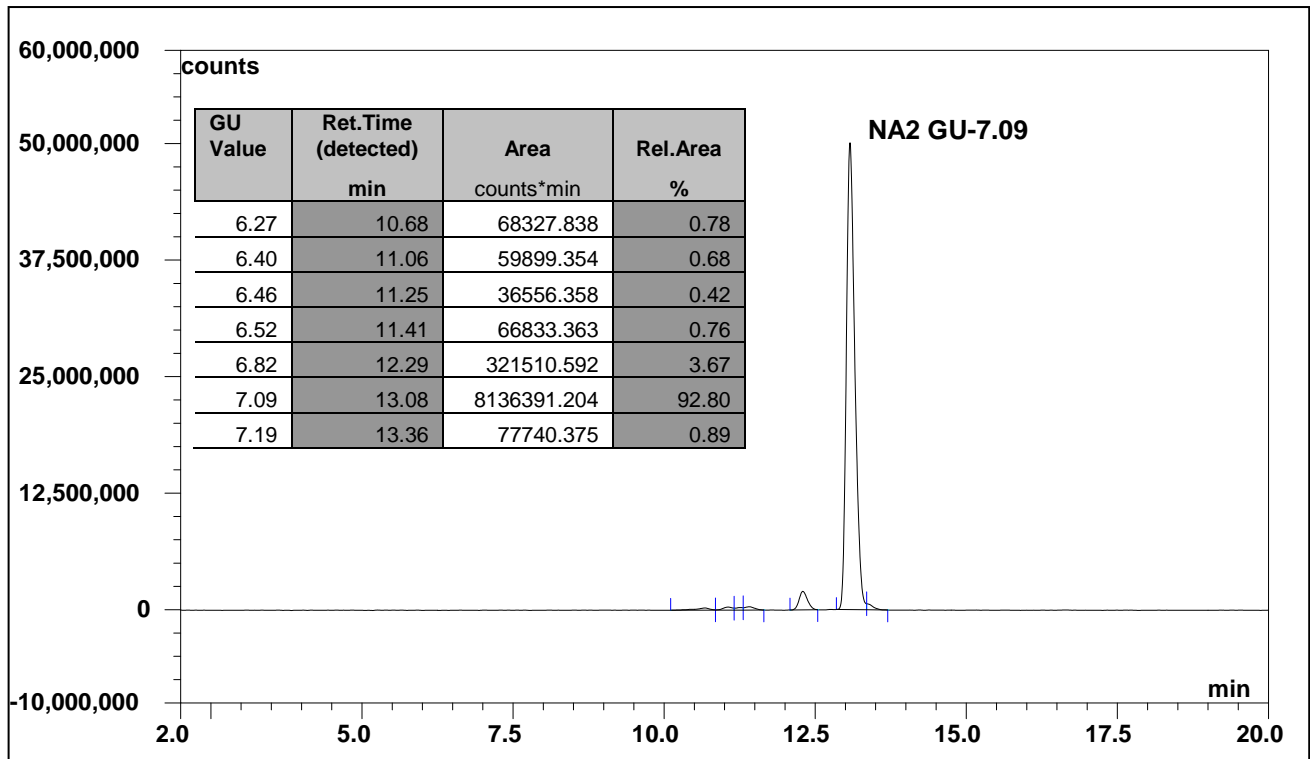

Figure 1: HILIC HPLC profile of 2AB labelled NA2 glycan (see method conditions below)
 (Cat. #: CAB-NA2-01, Batch B335-02).

**NA2 glycan structure identified by MALDI, MS & HPLC (GU value comparison to GlycoBase). This structure is drawn according to the scheme developed by Oxford-Dublin Glycobiology Laboratory (see Fig 2).*

2-AB NA2 peak seen above, eluted at 13.1 minutes, under the following conditions:

HPLC Running Conditions:

Column: Waters BEH Glycan 1.7µm column (150mm)

Flow: 0.56mL/min.

Temperature: 60 °C

Solvent A: 50mM ammonium formate pH 4.4 Solvent B: 100 % acetonitrile

Gradient:

Time (min)	%B
0.0	75.0
1.5	75.0
24.8	58.0
25.8	40.0
25.9	75.0
31.0	75.0

Detector: Dionex FLD-3000

Excitation wavelength: 250 nm

Emission wavelength: 428 nm

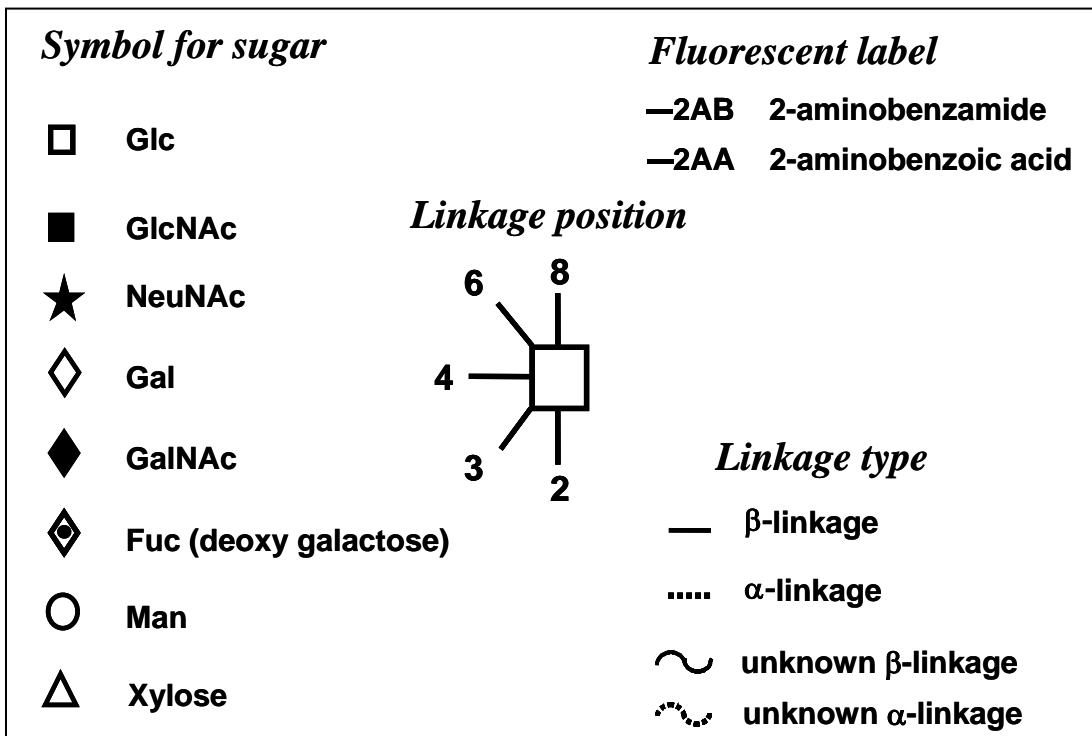

Figure 2: GlycoBase glycan structure key.